

	Incident Ray	Reflected Ray	Characteristics
1.			size =
2.			orientation =
3.			location =
4.			type =

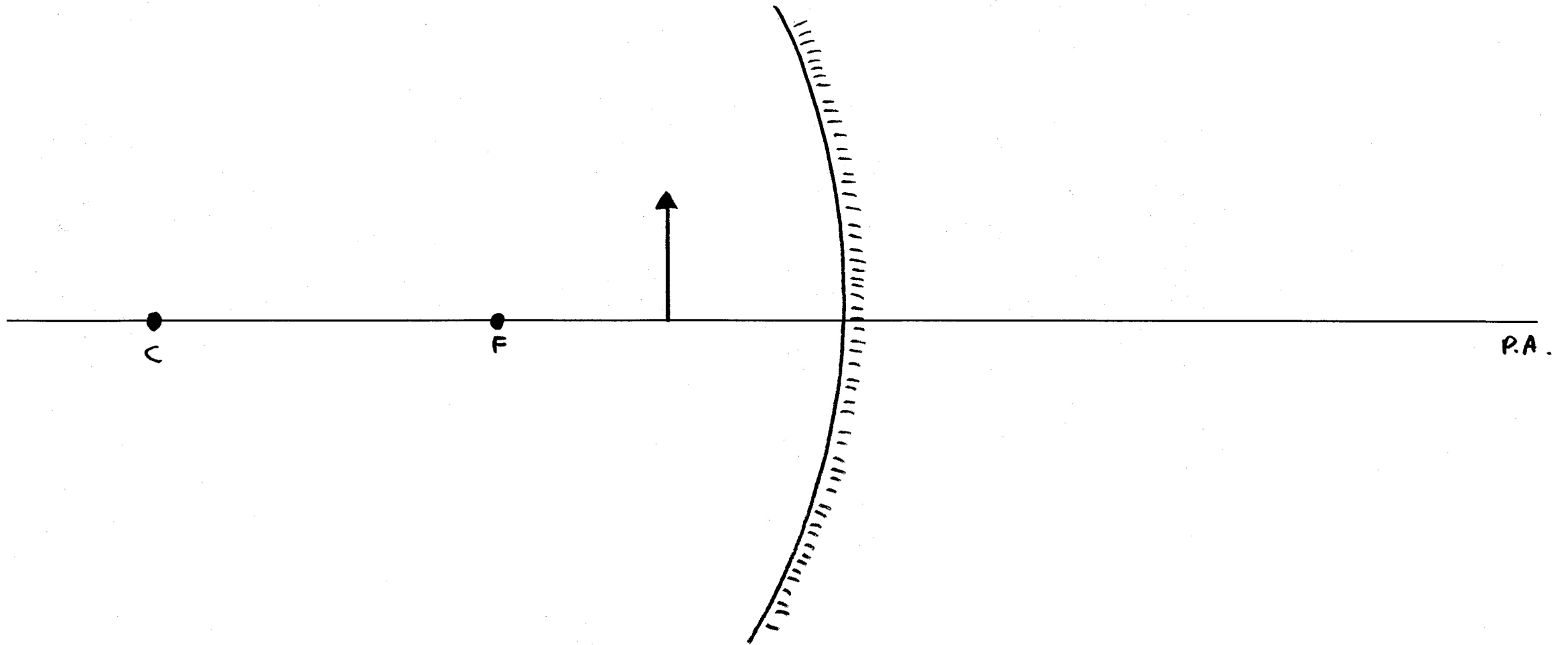

	Incident Ray	Reflected Ray	Characteristics
1.	parallel to principle axis	through focal point	size =
2.			orientation =
3.			location =
4.			type =

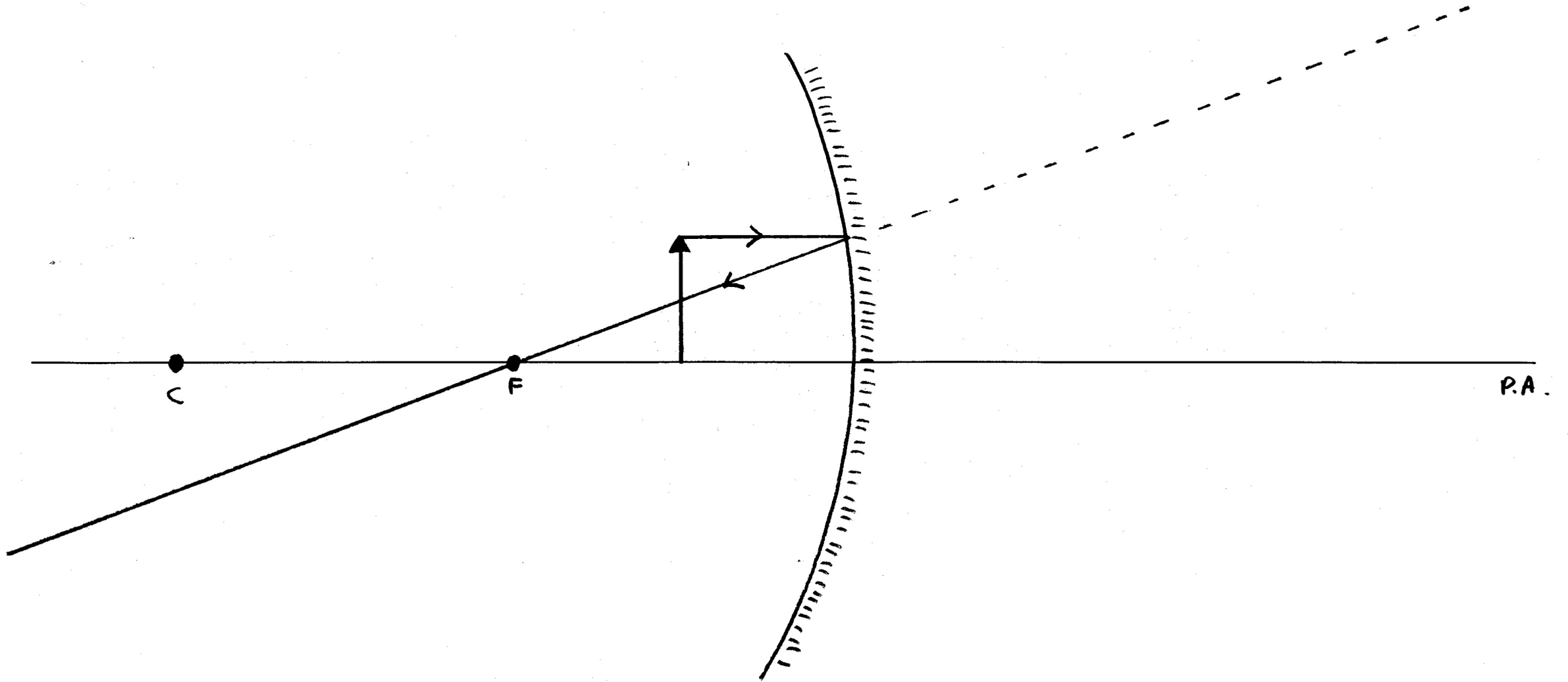

	Incident Ray	Reflected Ray	Characteristics
1.	parallel to principle axis	through focal point	size =
2.	through or in line with focal point	parallel to principle axis	orientation =
3.			location =
4.			type =

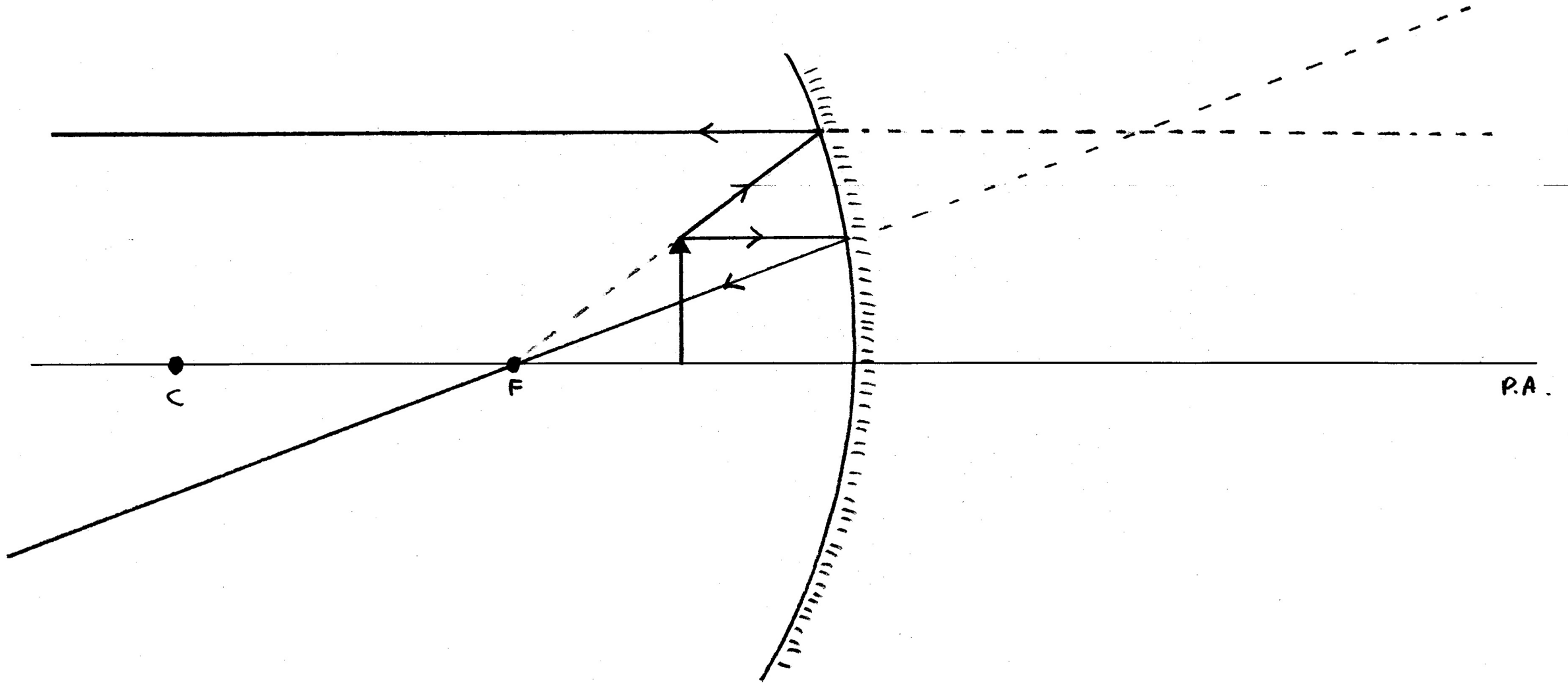

	Incident Ray	Reflected Ray	Characteristics
1.	parallel to principle axis	through focal point	size =
2.	through or in line with focal point	parallel to principle axis	orientation =
3.	through or in line with centre of curvature	through centre of curvature	location =
4.			type =

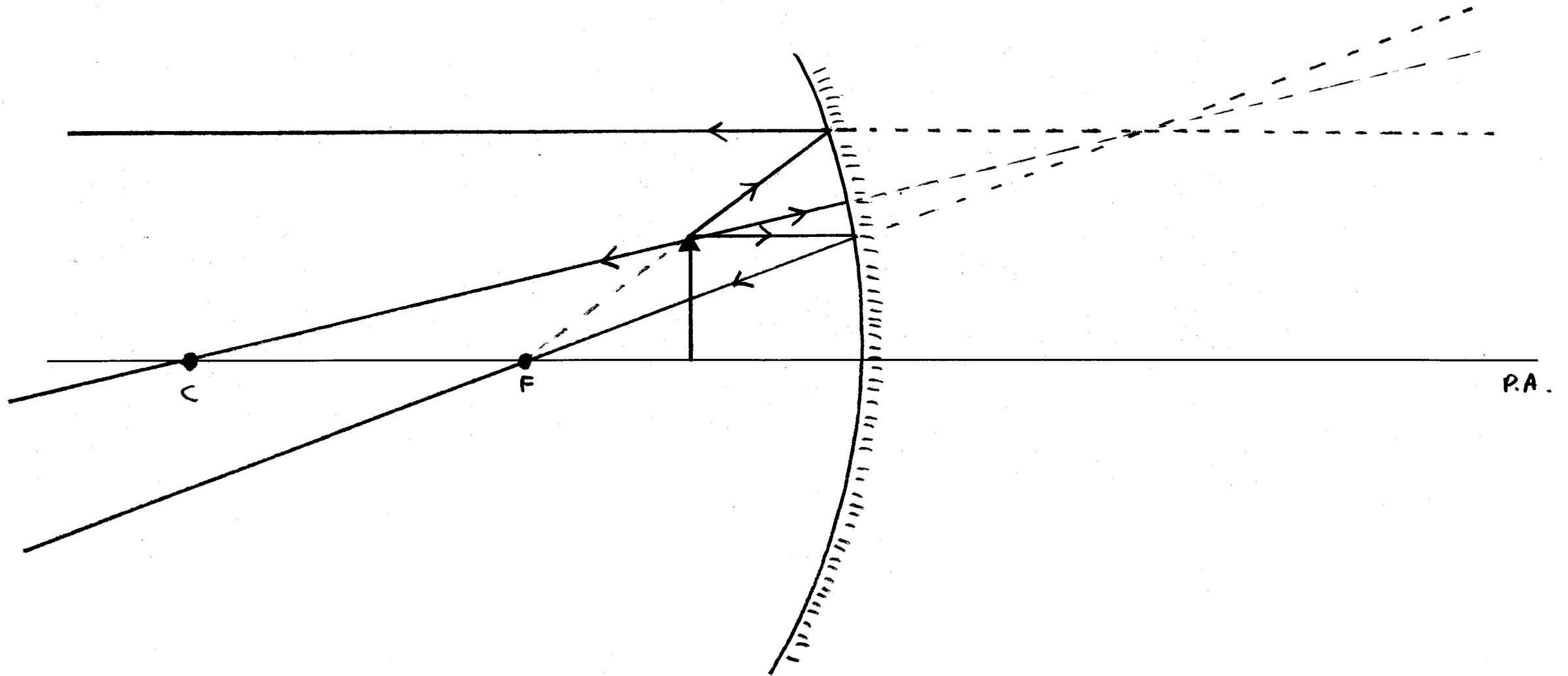

	Incident Ray	Reflected Ray	Characteristics
1.	parallel to principle axis	through focal point	size =
2.	through or in line with focal point	parallel to principle axis	orientation =
3.	through or in line with centre of curvature	through centre of curvature	location =
4.	hits mirror at vertex	reflects with equal angle from the vertex	type =

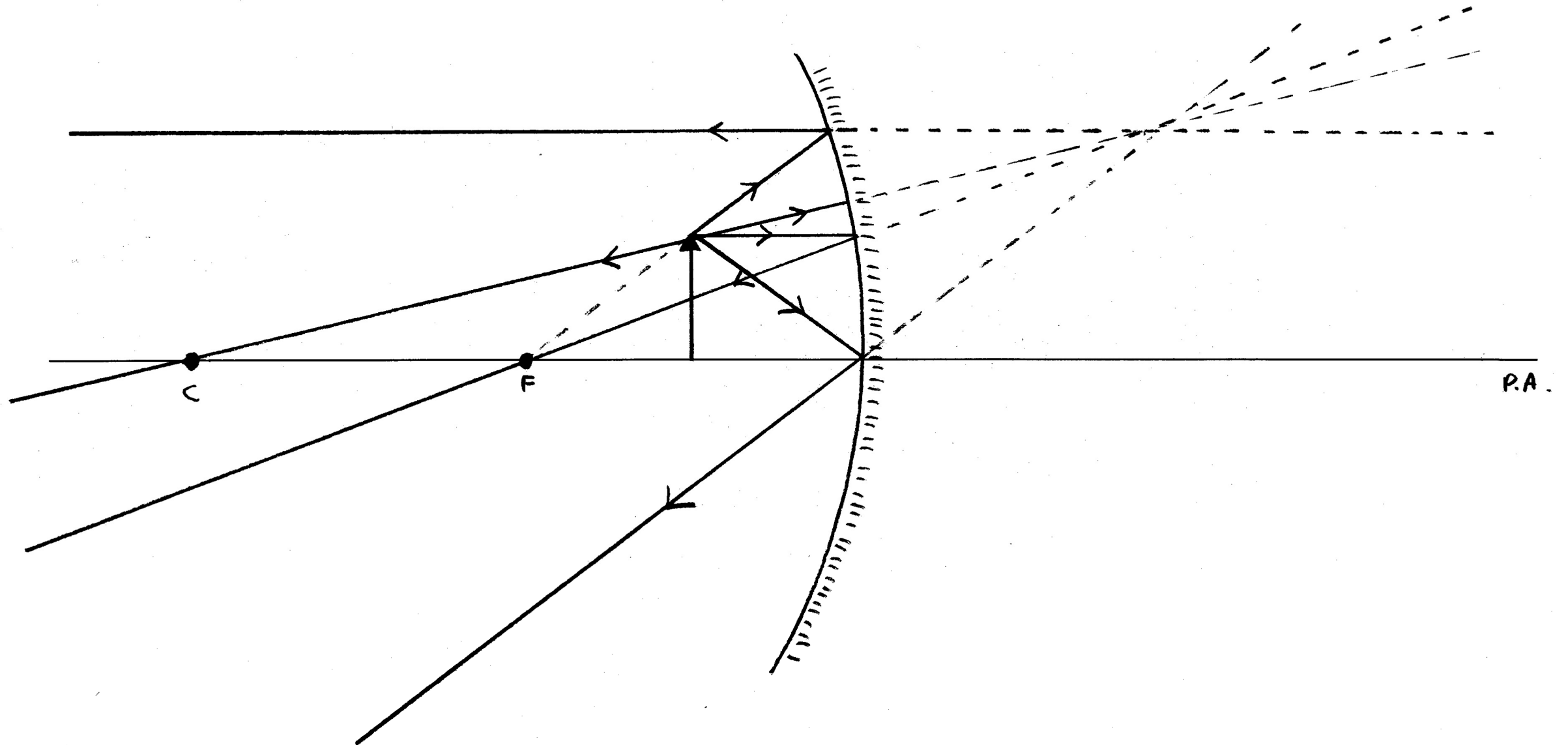

	Incident Ray	Reflected Ray	Characteristics
1.	parallel to principle axis	through focal point	size = larger
2.	through or in line with focal point	parallel to principle axis	orientation = same
3.	through or in line with centre of curvature	through centre of curvature	location = behind mirror
4.	hits mirror at vertex	reflects with equal angle from the vertex	type = virtual

